

Progressive scan CCD camera KP-FMR400WCL Specifications

1. General

KP-FMR400WCL CMOS camera is CameraLink output system progressive scan color camera that adopted 1-inch size CMOS sensor of a global shutter method with RGB primary color mosaic filter. The image of 2048 (H) x 2048 (V) is output at 150 frames per second.

The square lattice pixel format also provides excellent suitability for image processing applications.

2. Outstanding features

(1) High resolution

The 1-inch 4,000,000 pixels square lattice progressive scan CMOS and the RGB primary color mosaic filter achieve a high resolution and high color fidelity of 2048 (H) x 2048 (V).

(2) Small-sized camera

The camera has small SDR connector for digital outputs.

Therefore, the camera has the realization of small-sized shape of 44(W) x 44(H) x 41(D) mm.

(3) Remote control

- Multi-step global shutter (from 1/38 to 1/50000 second in 8 steps and Variable)
- Frame on demand (the image capture at desired timing using the external trigger signal)
- Partial scan (max eight places)

and other various functions are set by remote control via CameraLink cable.

(4) Automatic power supply change

The power supply through the camera link cable is possible from the PoCL frame grabber board. Because the power supply from the DCIN/SYNC connector is also possible, it is possible to make the camera work by using usual frame grabber board. The power supply from the DCIN/SYNC connector is given to priority when the power supply is supplied from both.

-	Jun 6, 2011	(first edition)	T. Ohsawa	T. Ohsawa
SYMBOL	DATE	DESCRIPTION	(DRAWN)	DESIGNED

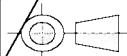
MODEL KP-FMR400WCL		TOLERANCE	Prod. Code - Order No	
DESIGNED	DATE	APPROVED	DATE	TITLE KP-FMR400WCL Specifications
<i>T. Ohsawa</i>	Jun 6, 11	<i>H. Igarashi</i>	Jun 6, 11	
CHECKED	DATE	STORED	DATE	
<i>K. Ueno</i>	Jun 6, 11	<i>H. Fujimura</i>	Jun 7, 11	REV. 0
Hitachi Kokusai Electric			DWG. No. E400272277	SHEET 1 / 27

3. Specifications

A	(1) Imaging device	1-inch global shutter CMOS
	Effective pixels	2048 (H) x 2048 (V)
	Pixel size	5.5 um (H) x 5.5 um (V) (square lattice)
	Color filter	RGB primary color mosaic filter
	(2) Sensing area	11.264 mm (H) x 11.264 (V)
	(3) Scanning system	Progressive
	(4) Frame rate	Max 150 frames/second (full pixel readout)
	(5) Pixel frequency	40.0000 MHz
B	(6) Horizontal scanning frequency	Full configuration (80MHz) : 310.078 kHz
		Full configuration (40MHz) : 155.039 kHz
		Medium configuration (80MHz) : 155.039 kHz
		Medium configuration (40MHz) : 77.519 kHz
		Base configuration (80MHz) : 77.519 kHz Base configuration (40MHz) : 38.759 kHz
C	(7) Vertical scanning frequency (full pixel readout)	Full configuration (80MHz) : 150.523 Hz
		Full configuration (40MHz) : 75.445 Hz
		Medium configuration (80MHz) : 75.445 Hz
		Medium configuration (40MHz) : 37.768 Hz
		Base configuration (80MHz) : 37.768 Hz Base configuration (40MHz) : 18.896 Hz
	(8) Sync system	Internal
	(9) Lens mount	C mount
D	(10) Flange focal distance	17.526 mm
	(11) Video output	Digital output (Camera Link)
		Base configuration 2TAP (80MHz or 40MHz)
Medium configuration 4TAP (80MHz or 40MHz) Full configuration 8TAP (80MHz or 40MHz)		
		Output image size: 2048(H) x 2048(V) (full pixel readout)
E	(12) Resolution	Horizontal/Vertical: 1400TV lines
	(13) Sensitivity	2000 lx, F16, 3200 K
	(14) Signal noise to ratio	48 dB
	(15) Electric shutter	OFF, 1/38, 1/100, 1/250, 1/500, 1/1000, 1/2000, 1/10000, 1/50000 second.
		OFF is normal exposure (frame rate) or changeable by variable shutter
F	(16) Gamma	$\gamma = 1$

(17) Frame on demand

Mode

(A) Fixed shutter mode (8 steps or variable)

(B) ONE trigger mode

(C) Burst trigger mode

Trigger input

CameraLink (CC1) or DCIN/SYNC connector

(18) Partial scan

Selectable start position and width of picture grabbing
in 1H step.

(19) Power supply voltage

12 ± 1 VDC

(20) Current consumption

Approx. 230 mA (Approx. 2.76W)

(21) Ambient

Performance

0 to +40 °C (+32 to +104 F), less than 90 % RH

Operation

-10 to +50 °C (+14 to 122 F), less than 90 % RH

Storage

-20 to +60 °C (-4 to 140 F), less than 70 % RH
(without dew condensation)

(22) Vibration endurance

10 to 55 Hz (2.37 to 71.7 m/s²), sweep: 1 min XYZ 30min

(23) Shock endurance

490.3 m/s² (Drop test, once each top, bottom, left and right)

(24) External dimensions

44 (W) x 44 (H) x 41 (D) mm (Not including protrusions)

(25) Mass

Approx. 130 g

(26) Remote control

(a) Signal system

Control system

Start-stop synchronization system

Transmission rate

9600 bps

Data length

8 bits

Start bit

1bit

Stop bit

1bit

Parity

None

Bit transfer

LSB first

(b) Communications control system

Full control by remote control software, data send/receive by text data transfer to camera
microprocessor (BSC system handshake)

(c) Control items

A

B

C

D

E

F

A

B

C

D

E

F

1. Shutter speed

OFF, 1/70, 1/100, 1/250, 1/500, 1/1000, 1/2000,
1/10000, 1/50000 second

Factory setting: OFF

2. Variable shutter

16.125 us to 211367 us

Factory setting: 26454.7 us

3. Multi shutter speed

Increase step of the exposure time and
number of frames of one cycle are set.

4. Mode

OFF, Fixed shutter, One trigger and Burst trigger mode

Factory setting: OFF

Number of frames can be set at burst trigger mode.

5. Vertical sub sampling

OFF(x1) / x2 / x3 / x4 / x5 / x6 / x7 / x8 / x9 / x10

Factory setting: OFF

6. Gain

x1 to x4

Factory setting: x1

7. 8bit / 10bit

Factory setting: 8bit

8. Partial scan (max 8 areas)

Selectable start position and width of picture grabbing
in 1H step.

Factory setting: OFF

9. Offset level

0/255 to 127/255

Factory setting: 0/255

10. Trigger pulse polarity

POSI / NEGA

Factory setting: POSI

11. Cameralink Configuration

Base / Medium / Full

Factory setting: Base

12. Cameralink clock

40MHz / 80MHz

Factory setting: 80MHz

13. Flip

OFF / H-FLIP / V-FLIP / HV-FLIP

Factory setting: OFF

14. Trigger input

CameraLink (CC1) or DCIN/SYNC connector

Factory setting: CC1

15. Output signal

OFF, FLASH OUT and VD OUT

Factory setting: OFF

16. Test pattern

OFF / H-LAMP / V-LAMP / HV-LAMP

Factory setting: OFF

17. Factory set

Return to the factory settings.

4. Composition

- (1) Camera (with IR cut filter)
 (2) Composition table

5. Optional accessories

- (1) Junction box JU-F30
 (2) 12pin plug HR10A-10P-12S(01)
 (3) Dummy glass (AR coated) ARC1616
 (4) IR cut filter IRC1616
 (5) Tripod adaptor TA-FM200
 (6) Camera cable

	Molded type	Shield type
2 m	C-201KSM	C-201KSS
5 m	C-501KSM	C-501KSS
10 m	C-102KSM	C-102KSS

In the CE Marking region, use the shield type and install clamp filter (ZCAT2035-0930A: TDK) at both ends of the cable.

(7) Digital out cable

Cable length	Model name	
	SDR-SDR type	SDR-MDR type
1m	C-101PCL (SS)	C-101PCL (SM)
2m	C-201PCL (SS)	C-201PCL (SM)
3m	C-301PCL (SS)	C-301PCL (SM)
5m	C-501PCL (SS)	C-501PCL (SM)

SDR: Shrunk Delta Ribbon

MDR: Miniature Delta Ribbon

(note) Please use the cable only for Full configuration separately when using it with Full configuration.

6. Signal connection to connector

(1) Signal connection to DCIN/SYNC connector

PIN No.	Internal SYNC mode	PIN No.	Internal SYNC mode
1	GND	7	Trigger IN/ VD IN
2	---- (PoCL)	8	GND
	+12V (non-PoCL)		
3	GND	9	----
4	----	10	FLASH OUT / VD OUT
5	GND	11	----
6	----	12	GND

Plug (matching cable plug) Hirose HR10A-10P-12S(01) or equivalent

(Note) Please do not unplug and insert cable (camera cable) with a power supplied to a camera.
Install clamp filter (ZCAT 2035-0930A: TDK) at both ends (camera and video processor ends) in the CE marking region.

(2) Signal connection to DIGITAL OUT connector

D.OUT 1

Pin No.	Signal	Pin No.	Signal
1	+12V (PoCL)	14	GND
	GND (non-PoCL)		
2	TXOUT 0 (-)	15	TXOUT 0 (+)
3	TXOUT 1 (-)	16	TXOUT 1 (+)
4	TXOUT 2 (-)	17	TXOUT 2 (+)
5	TXCLKOUT (-)	18	TXCLKOUT (+)
6	TXOUT 3 (-)	19	TXOUT 3 (+)
7	RX (+) [SERTC (+)]	20	RX (-) [SERTC (-)]
8	TX (-) [SERTFG (-)]	21	TX (+) [SERTFG (+)]
9	TRIG (-) [CC1 (-)]	22	TRIG (+) [CC1 (+)]
10	NC [CC2 (+)]	23	NC [CC2 (-)]
11	NC [CC3 (-)]	24	NC [CC3 (+)]
12	NC [CC4 (+)]	25	NC [CC4 (-)]
13	GND	26	+12V (PoCL)
			GND (non-PoCL)

D.OUT 2

Pin No.	Signal	Pin No.	Signal
1	+12V (PoCL)	14	GND
	GND (non-PoCL)		
2	TYOUT 0 (-)	15	TYOUT 0 (+)
3	TYOUT 1 (-)	16	TYOUT 1 (+)
4	TYOUT 2 (-)	17	TYOUT 2 (+)
5	TYCLKOUT (-)	18	TYCLKOUT (+)
6	TYOUT 3 (-)	19	TYOUT 3 (+)
7	100Ω (+)	20	100Ω (+)
8	TZOUT 0 (-)	21	TZOUT 0 (+)
9	TZOUT 1 (-)	22	TZOUT 1 (+)
10	TZOUT 2 (-)	23	TZOUT 2 (+)
11	TZCLKOUT (-)	24	TZCLKOUT (+)
12	TZOUT 3 (-)	25	TZOUT 3 (+)
13	GND	26	+12V (PoCL)
			GND (non-PoCL)

Connector (camera side)

Sumitomo 3M 1226-1100-00PL or equivalent

N.U.: Not used

- D.OUT2 is used for Medium configuration or Full configuration..
 - The digital out cable should be comprised of a twisted pair of wires having 100 ohm characteristic impedance and an outer sheath shield type conductor.
 - Connect the shield (ground) of the digital out cable to the ground terminal of the video equipment, frame grabber, etc.
 - Install clamp filter (ZCAT2035-0930A: TDK) at both ends (camera and video processor ends) in the CE marking region.
 - TX: Transmit data from camera to machine
 - RX: Transmit data from machine to camera
- (Note) Please do not unplug and insert cable (digital out cable) with a power supplied to a camera.

7. CameraLink output

7-1. Horizontal timing

(1) 80MHz Base configuration (1 clk = 12.5 ns)

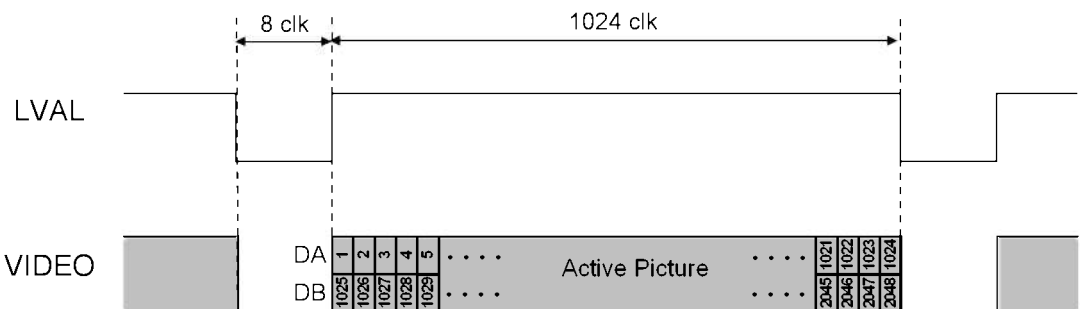

(2) 40MHz Base configuration (1 clk = 25 ns)

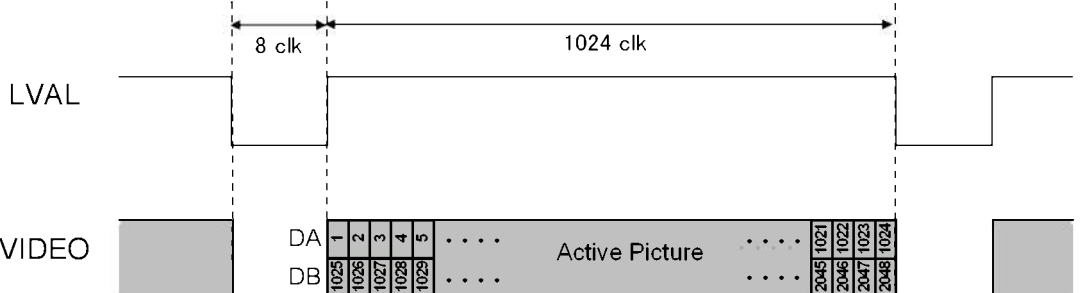

(3) 80MHz Medium configuration (1 clk = 12.5 ns)

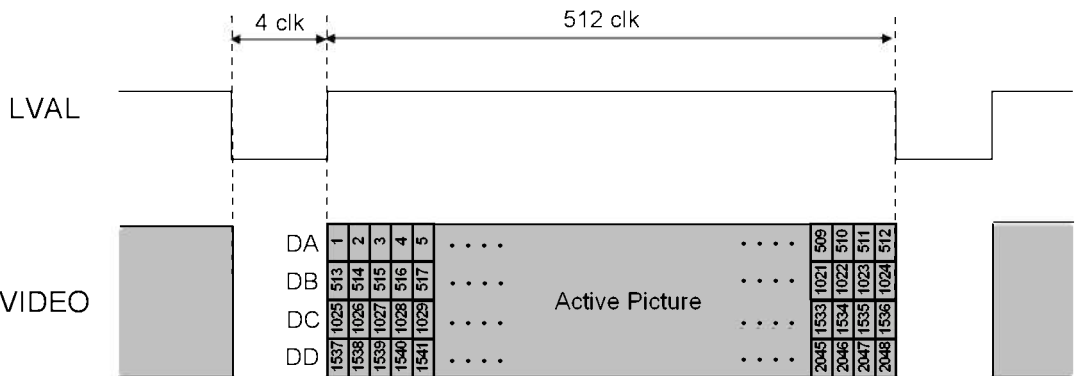

(4) 40MHz Medium configuration (1 clk = 25 ns)

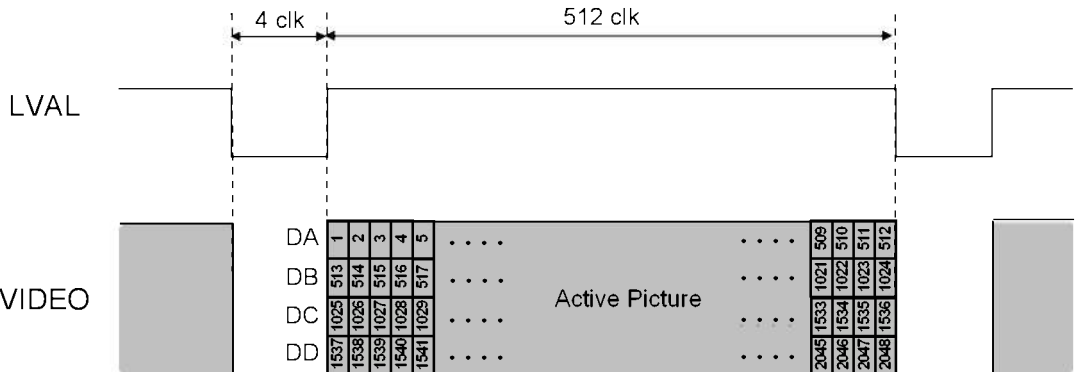

(5) 80MHz Full configuration (1 clk = 12.5 ns)

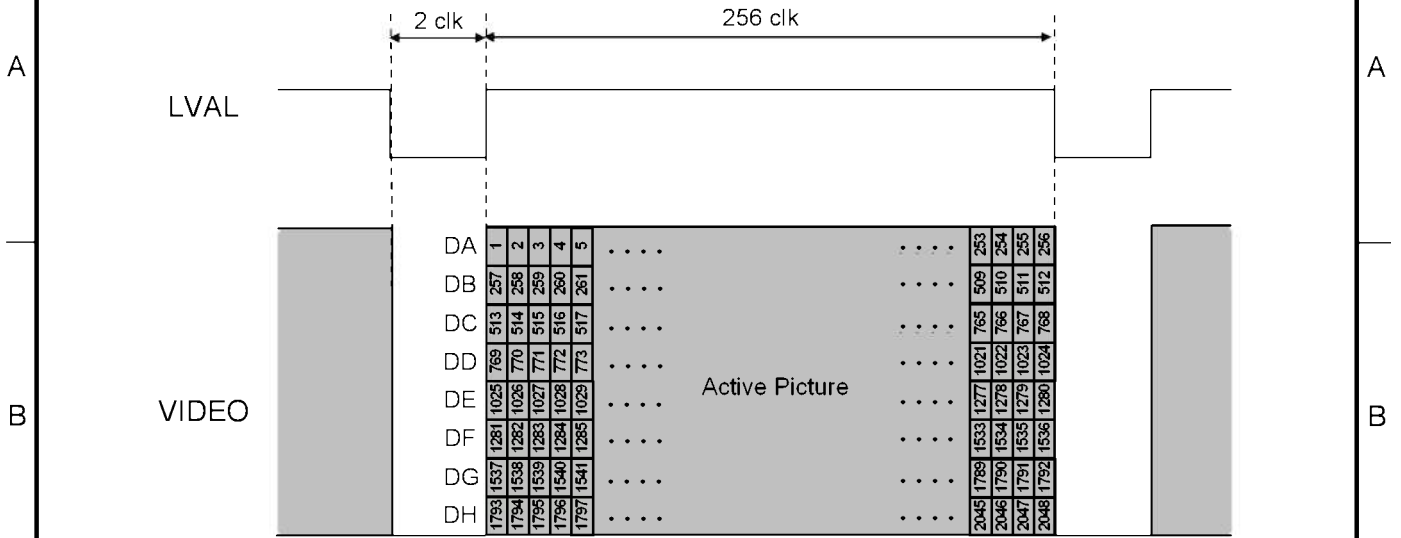

(6) 40MHz Full configuration (1 clk = 25 ns)

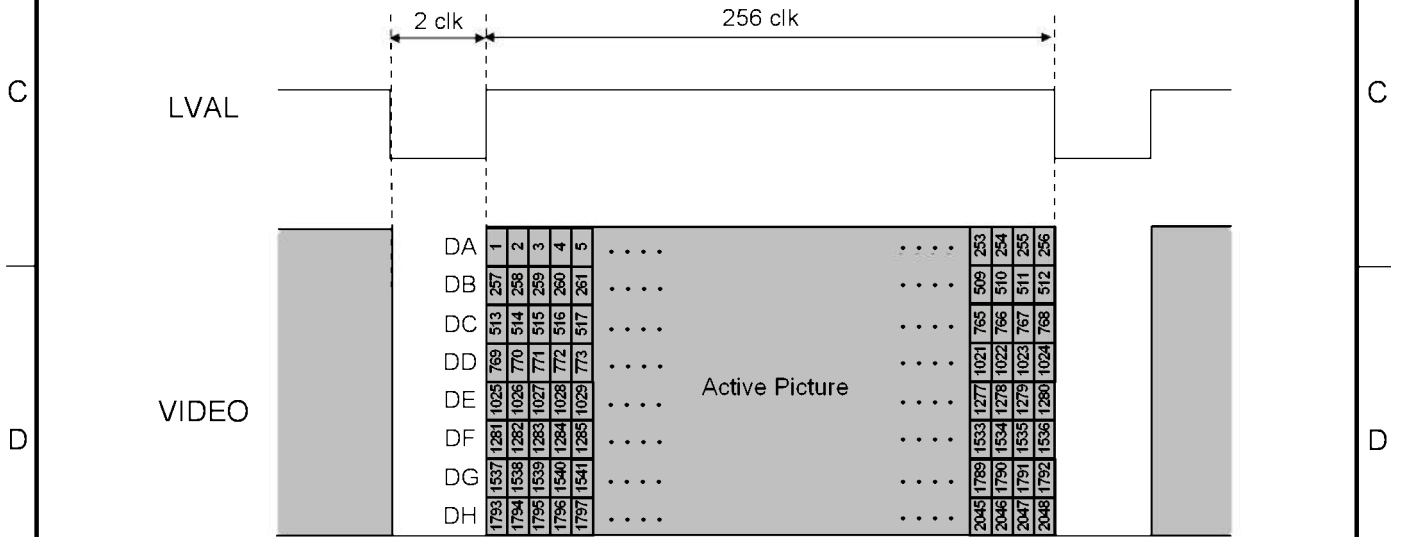

7-2. Vertical timing

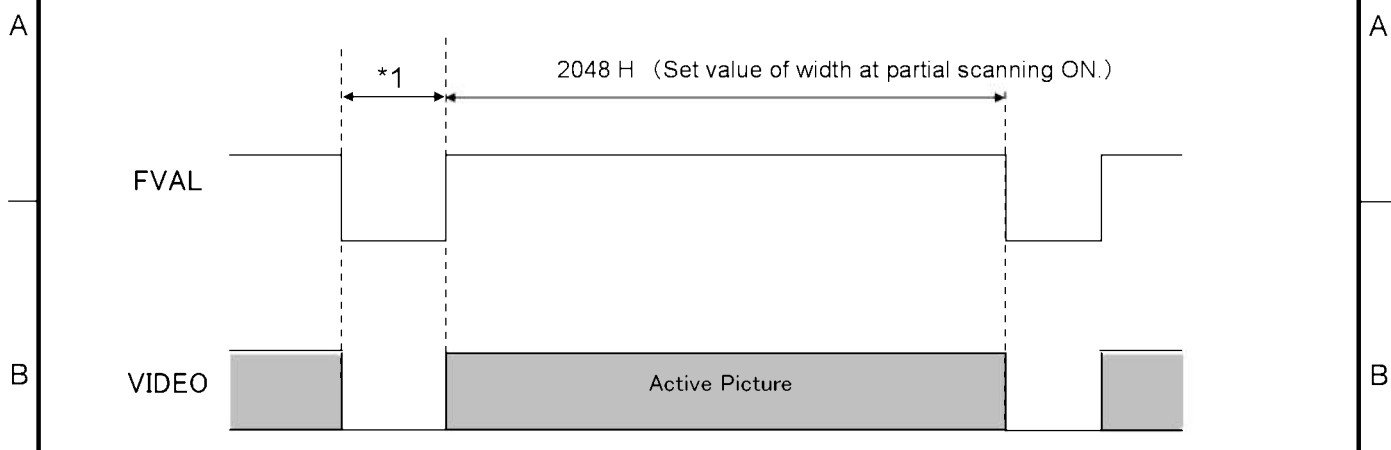

One horizontal period and blanking period (*1) are different because of the setting of the configuration and the clock frequency.

Cameralink output setting	One horizontal period	Blanking period (*1)
Base configuration 40MHz	1H = 25.800μs	3.25H
Base configuration 80MHz	1H = 12.900μs	4.5H
Medium configuration 40MHz	1H = 12.900μs	4.5H
Medium configuration 80MHz	1H = 6.450μs	7H
Full configuration 40MHz	1H = 6.450μs	7H
Full configuration 80MHz	1H = 3.225μs	12H

7-3. Transmitter LVDS output pulse position measurement

(1) Base configuration

(a) 8bit

A

A

D.OUT1

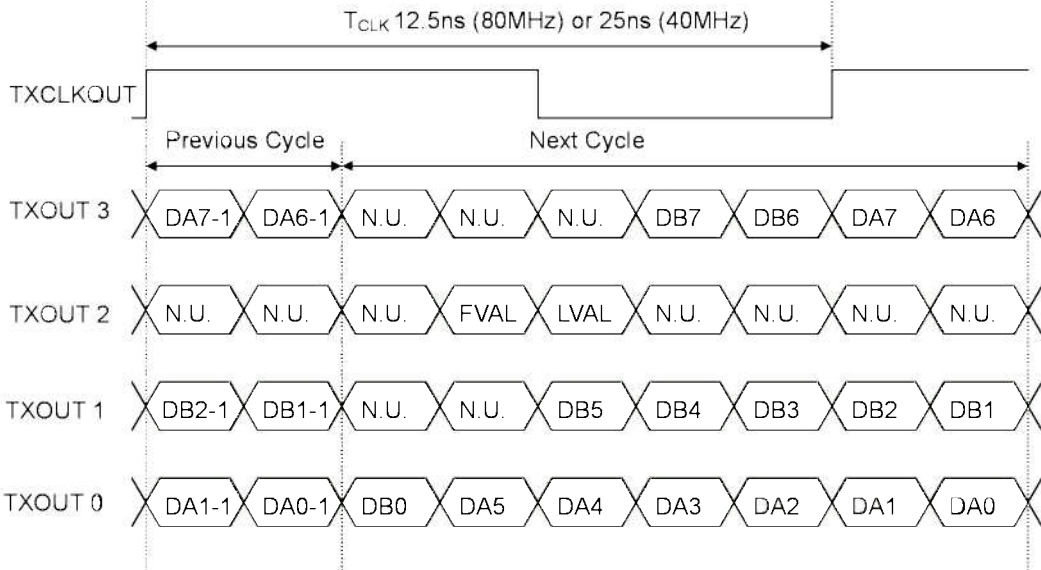

N.U.: Not used

C

C

(b) 10bit

D.OUT1

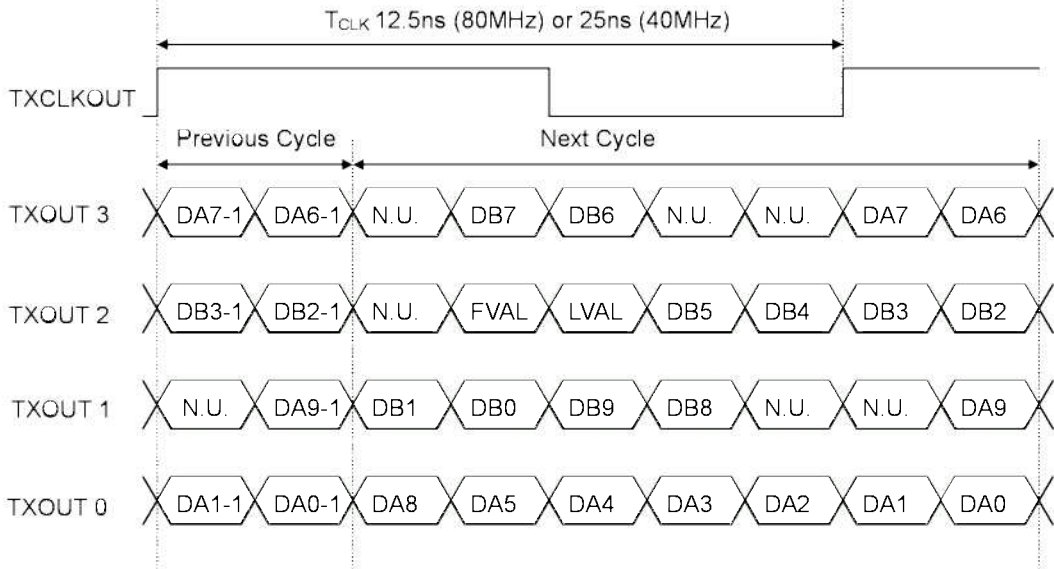

N.U.: Not used

D

D

E

E

* When using Base configuration, please be sure to connect to CameraLink cable to D.OUT1.
 If the cable is connected to D.OUT2, the machine may break down.

F

F

(2) Medium configuration

(a) 8bit

D.OUT1

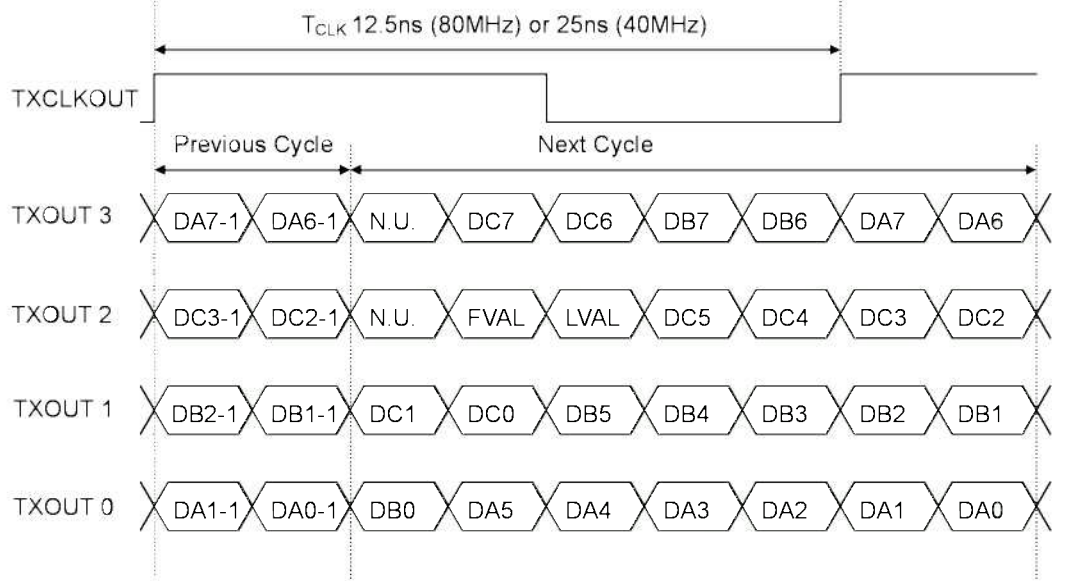

N.U.: Not used

D.OUT2

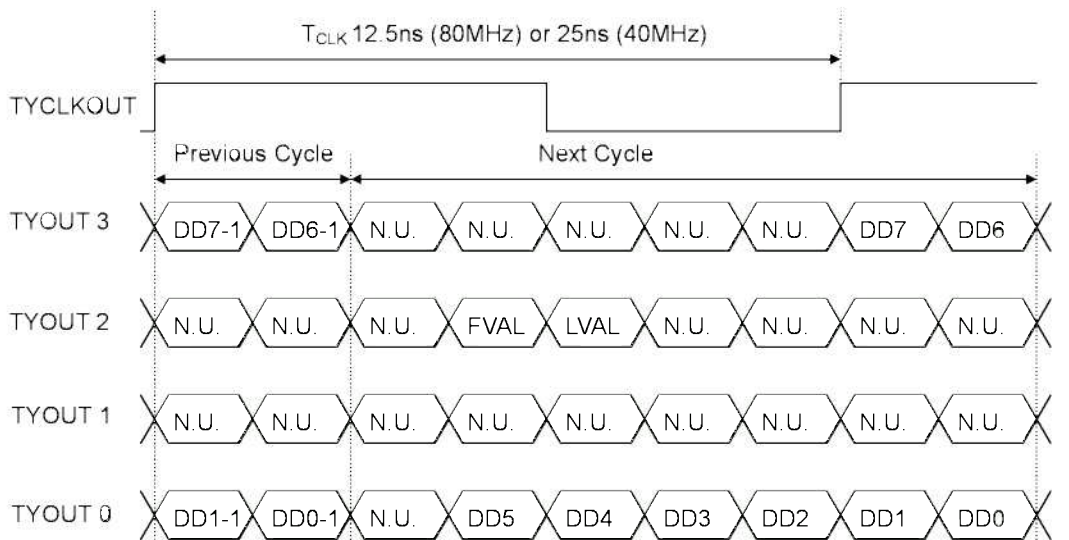

N.U.: Not used

(b) 10bit

A

D.OUT1

B

C

D

E

F

A

B

C

D

E

F

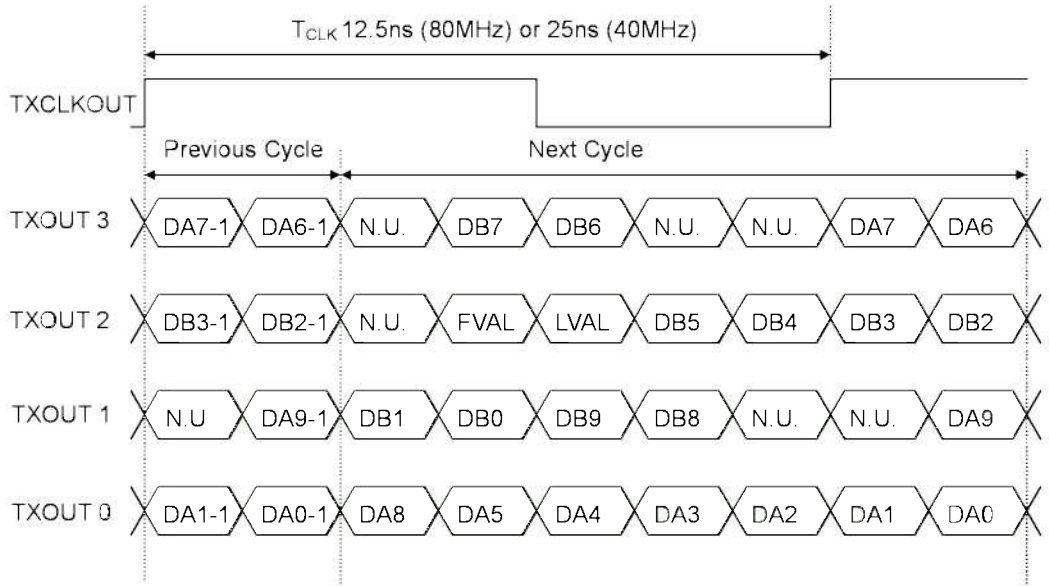

N.U.: Not used

D.OUT2

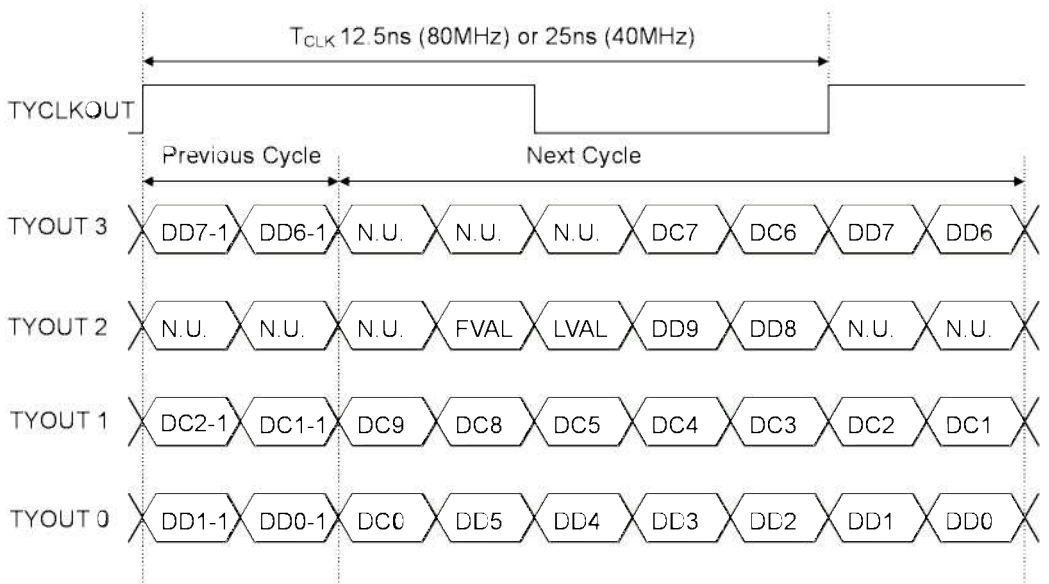

N.U.: Not used

(2) Full configuration

(a) 8bit

A

D.OUT1

T_{CLK} 12.5ns (80MHz) or 25ns (40MHz)

TXCLKOUT

Previous Cycle

Next Cycle

TXOUT 3

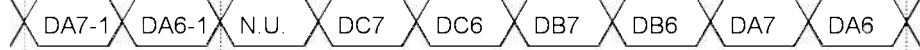

TXOUT 2



TXOUT 1

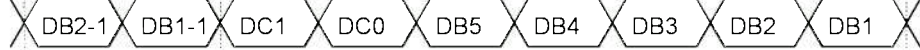

TXOUT 0

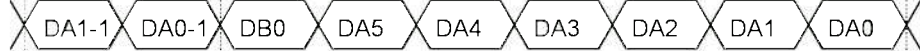

N.U.: Not used

B

C

D.OUT2

T_{CLK} 12.5ns (80MHz) or 25ns (40MHz)

TYCLKOUT

Previous Cycle

Next Cycle

TYOUT 3



TYOUT 2



TYOUT 1

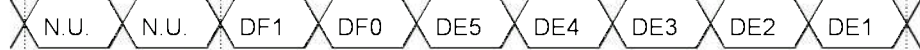

TYOUT 0



D

E

T_{CLK} 12.5ns (80MHz) or 25ns (40MHz)

TZCLKOUT

Previous Cycle

Next Cycle

TZOUT 3



TZOUT 2



TZOUT 1

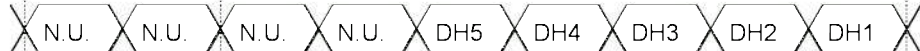

TZOUT 0



N.U.: Not used

F

7-4. Output sequence

DA, DB, DC, DD, DE, DF, DG and DH show output TAP of the cameralink.
Refer to " Transmitter LVDS output pulse position measurement " for details.

A

A

(1) Base configuration

B

B

C

C

D

D

E

E

F

F

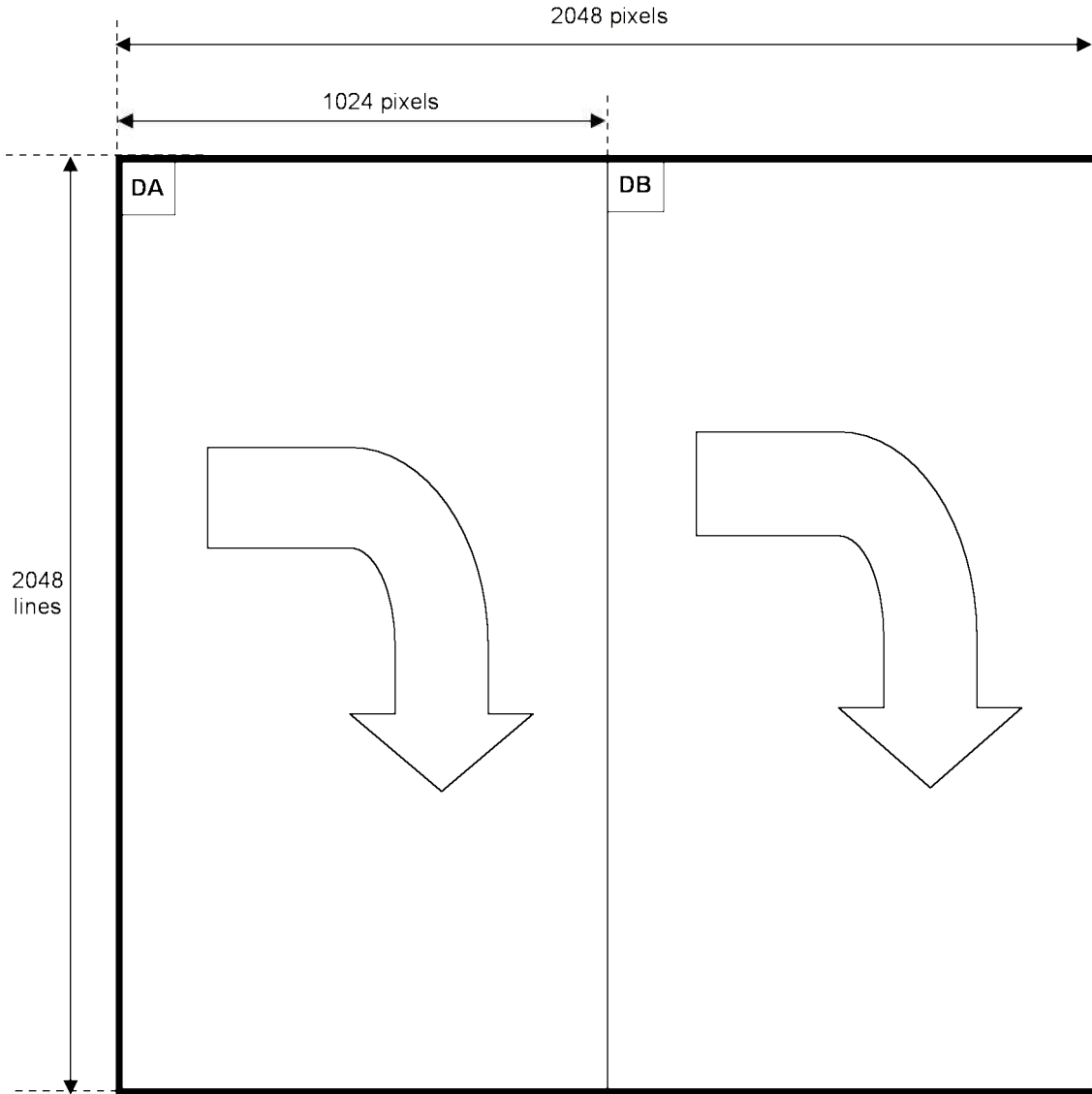

(2) Medium configuration

A

B

C

D

E

F

A

B

C

D

E

F

2048 pixels

512 pixels

2048 lines

DA

DB

DC

DD

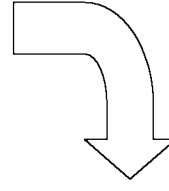
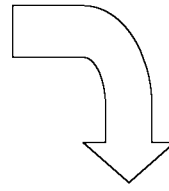
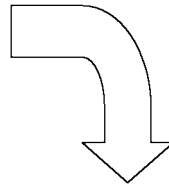
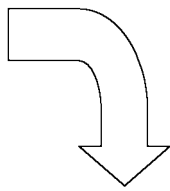

DWG.
No.

E400272277

SHEET
16 / 27

(3) Full configuration

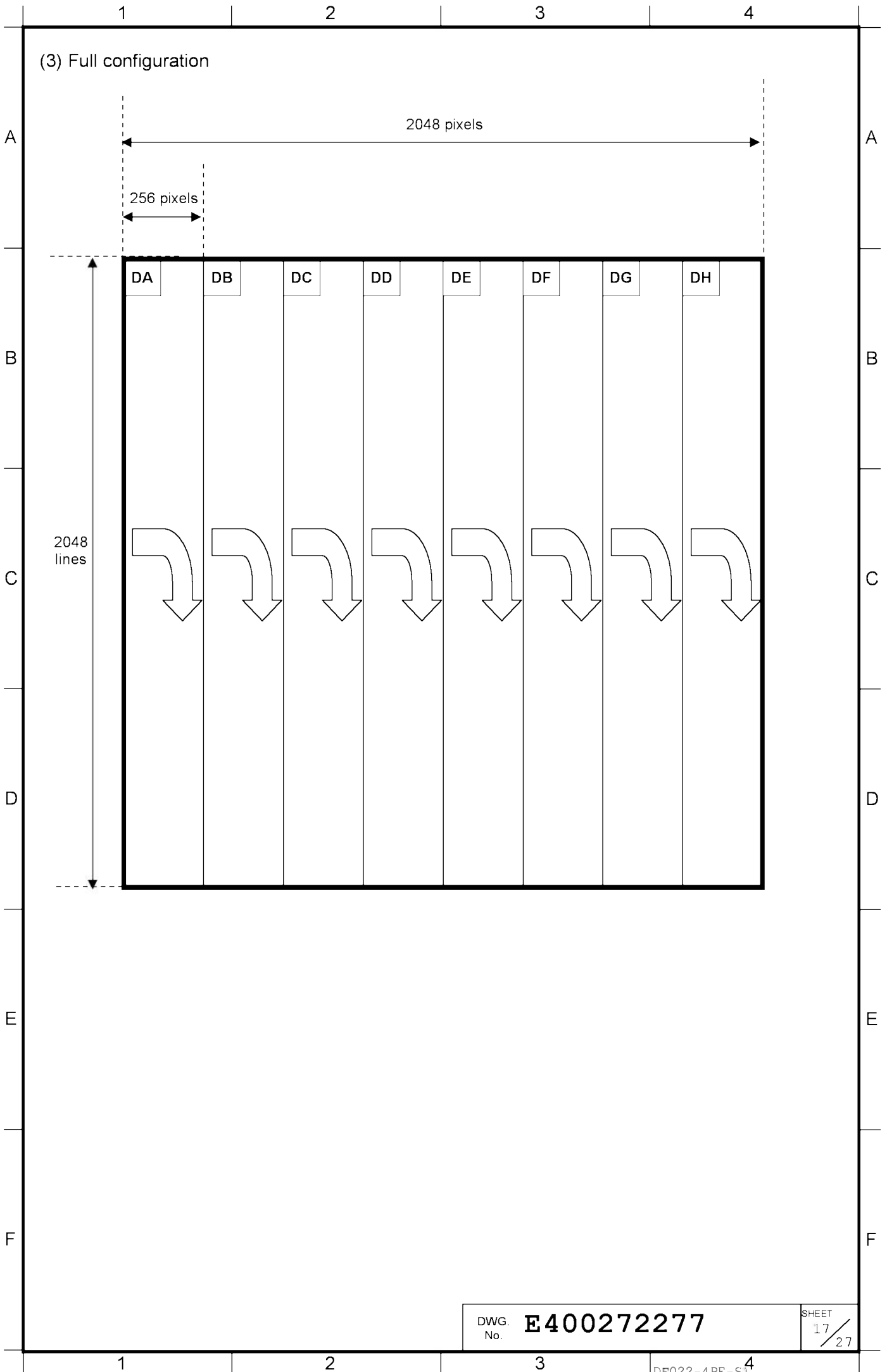

DWG. No. **E400272277**

SHEET
17 / 27

7-5. Output order of color pixel array

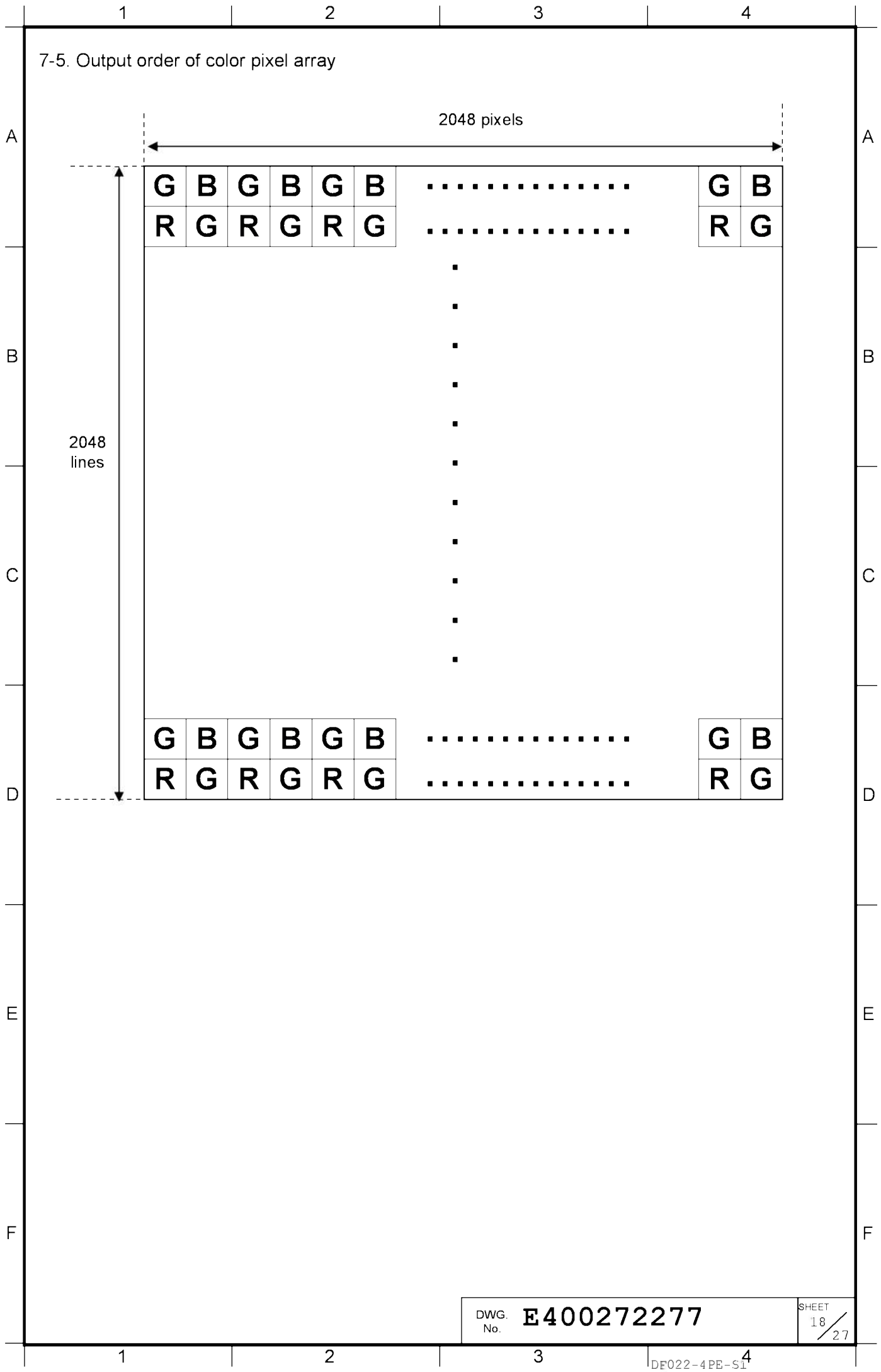

DWG. No. **E400272277**

SHEET 18 / 27

8. Timing chart

8-1. Normal mode

The exposure and the image output are repeated at the set shutter speed.
 When the multi shutter speed is set, exposure time (Shutter time) increases every one frame, and one cycle's worth of an image is output repeatedly.

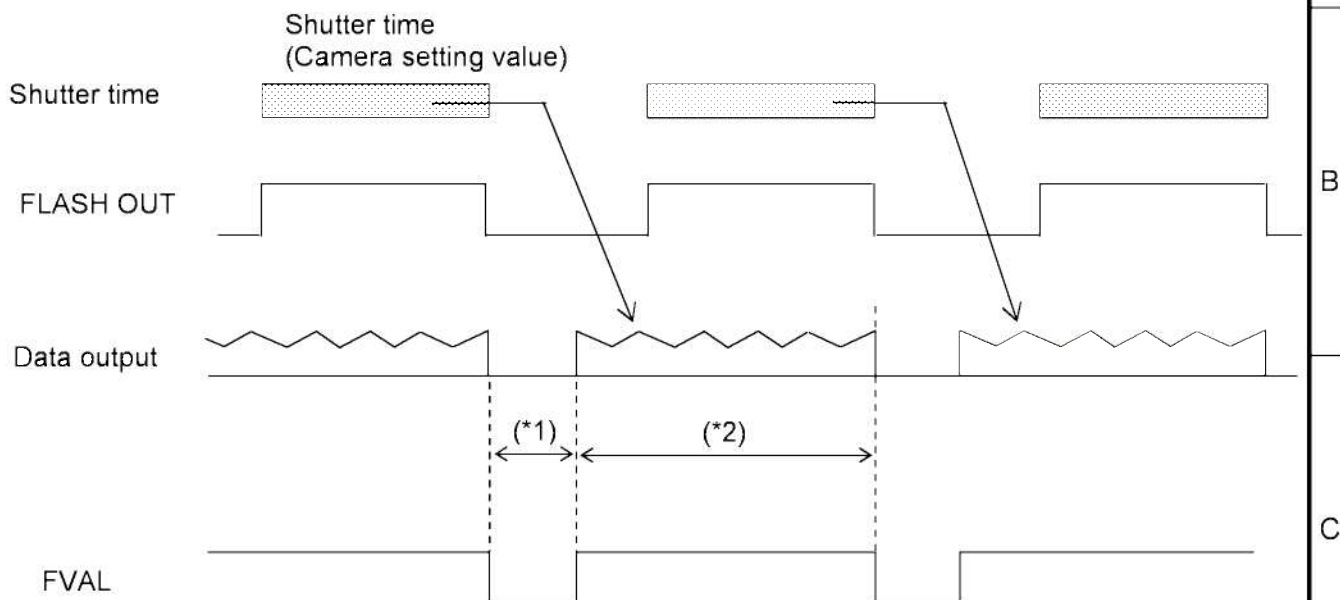

One horizontal period and blanking period (*1) are different because of the setting of the configuration and the clock frequency.

Cameralink output setting	One horizontal period	Blanking period (*1)
Base configuration 40MHz	1H = 25.800 μ s	3.25H
Base configuration 80MHz	1H = 12.900 μ s	4.5H
Medium configuration 40MHz	1H = 12.900 μ s	4.5H
Medium configuration 80MHz	1H = 6.450 μ s	7H
Full configuration 40MHz	1H = 6.450 μ s	7H
Full configuration 80MHz	1H = 3.225 μ s	12H

(*2) is 2048H at partial scan OFF, and set value of width at partial scan ON.

Frame rate can be calculated from following equations using width of picture grabbing.

Cameralink output setting	Total lines	Frame rate(fps)
Base configuration 40MHz	$(Width+3.25)H$	$40000000/(Width+3.25)/1032$
Base configuration 80MHz	$(Width+4.5)H$	$40000000/(Width+4.5)/516$
Medium configuration 40MHz	$(Width+4.5)H$	$40000000/(Width+4.5)/516$
Medium configuration 80MHz	$(Width+7)H$	$40000000/(Width+7)/258$
Full configuration 40MHz	$(Width+7)H$	$40000000/(Width+7)/258$
Full configuration 80MHz	$(Width+12)H$	$40000000/(Width+12)/129$

Graph following shows frame rate in each of picture grabbing in the partial scan mode.

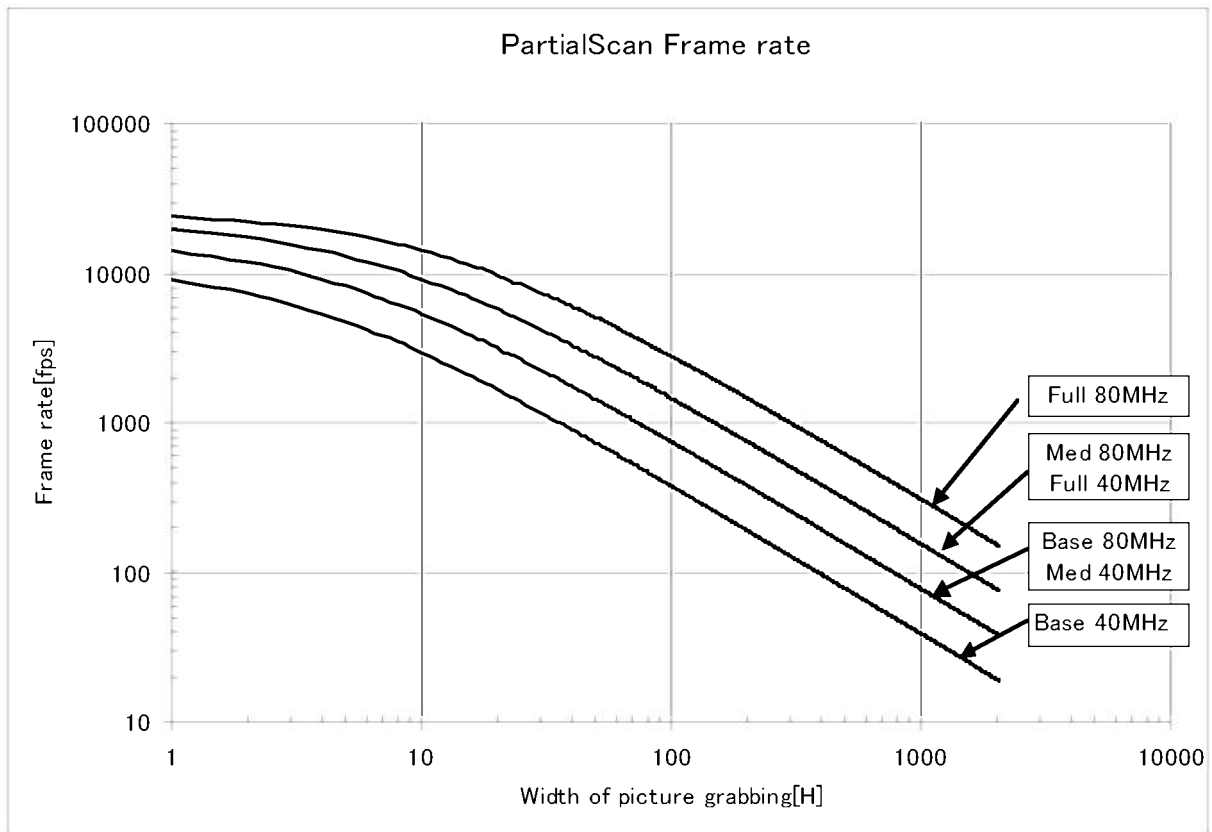

8-2. Fixed shutter mode

When external trigger signal is POSITIVE, after the trigger signal rise, exposure is start. The exposure time is set by the camera electronic shutter speed. The video output is obtained immediately after the end of fixed exposure.

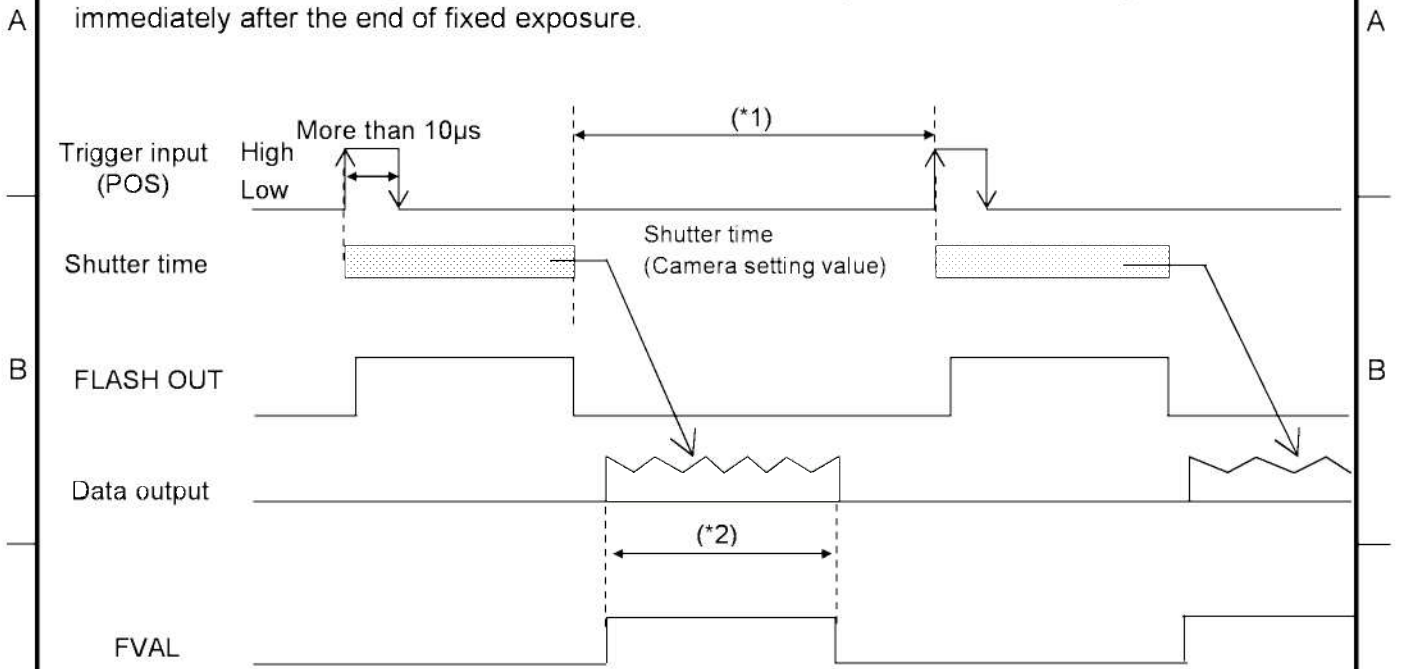

One horizontal period and Period from exposure end to the following trigger input (*1) are different because of the setting of the configuration and the clock frequency.

Cameralink output setting	One horizontal period	(*1)
Base configuration 40MHz	1H = 25.800μs	More than (*2) + 3.25H
Base configuration 80MHz	1H = 12.900μs	More than (*2) + 4.5H
Medium configuration 40MHz	1H = 12.900μs	More than (*2) + 4.5H
Medium configuration 80MHz	1H = 6.450μs	More than (*2) + 7H
Full configuration 40MHz	1H = 6.450μs	More than (*2) + 7H
Full configuration 80MHz	1H = 3.225μs	More than (*2) + 12H

(*2) is 2048H at partial scan OFF, and set value of width at partial scan ON.

8-3. ONE trigger mode

When external trigger signal is POSITIVE, after the trigger signal rise, exposure is start. At the trigger signal falling edge, the internal VD signal is reset and the video data are transmitted. The trigger signal width equals the exposure time.

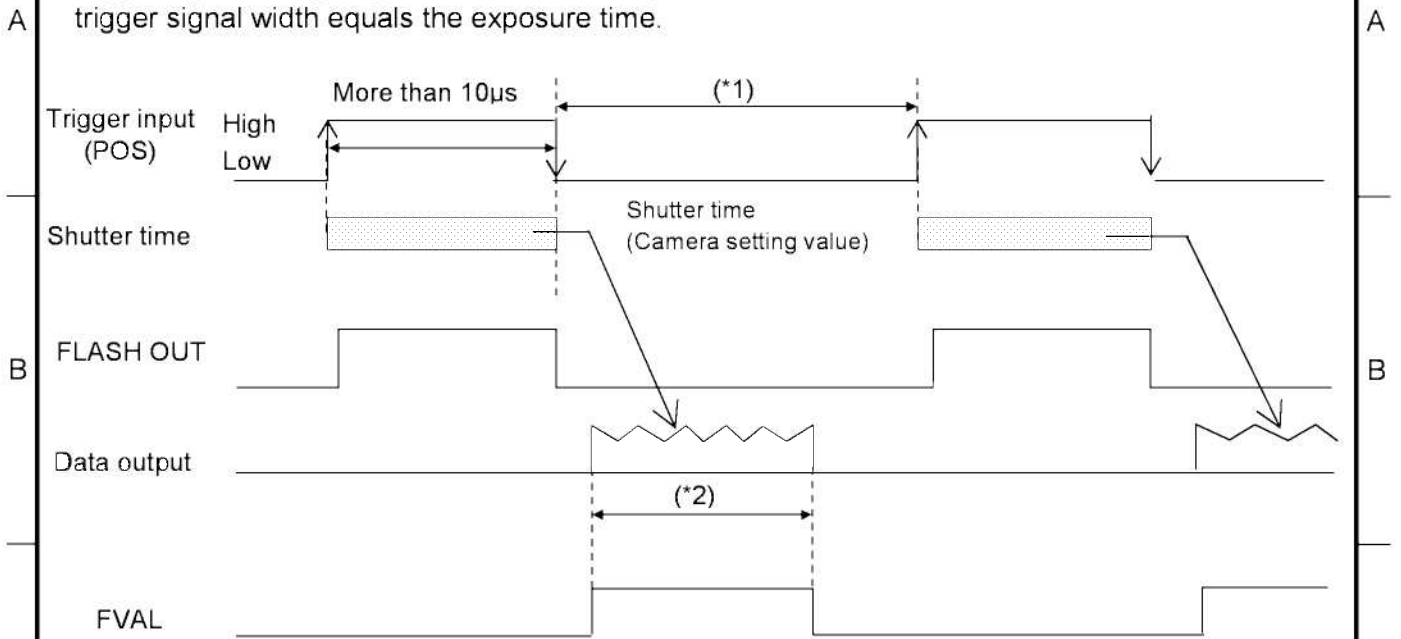

One horizontal period and Period from exposure end to the following trigger input (*1) are different because of the setting of the configuration and the clock frequency.

Cameralink output setting	One horizontal period	(*1)
Base configuration 40MHz	1H = 25.800 μ s	More than (*2) + 3.25H
Base configuration 80MHz	1H = 12.900 μ s	More than (*2) + 4.5H
Medium configuration 40MHz	1H = 12.900 μ s	More than (*2) + 4.5H
Medium configuration 80MHz	1H = 6.450 μ s	More than (*2) + 7H
Full configuration 40MHz	1H = 6.450 μ s	More than (*2) + 7H
Full configuration 80MHz	1H = 3.225 μ s	More than (*2) + 12H

(*2) is 2048H at partial scan OFF, and set value of width at partial scan ON.

8-4. Burst trigger mode

When external trigger signal is POSITIVE, after the trigger signal rise, exposure is start. The exposure time is set by the camera electronic shutter speed. The video output is obtained immediately after the end of fixed exposure. Thereafter, images of the set number of burst-frame are continuously output. When the multi shutter speed is set, exposure time (Shutter time) increases every one frame, and one cycle's worth of an image is output repeatedly.

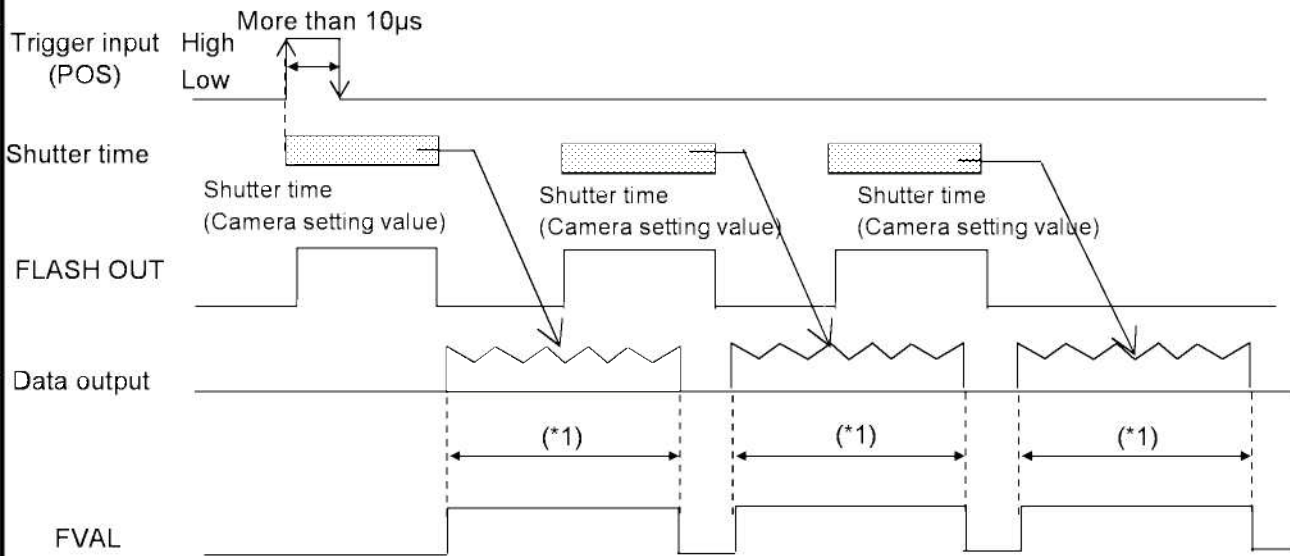

(*1) is 2048H at partial scan OFF, and set value of width at partial scan ON.

9. Spectral response

A

B

C

D

E

F

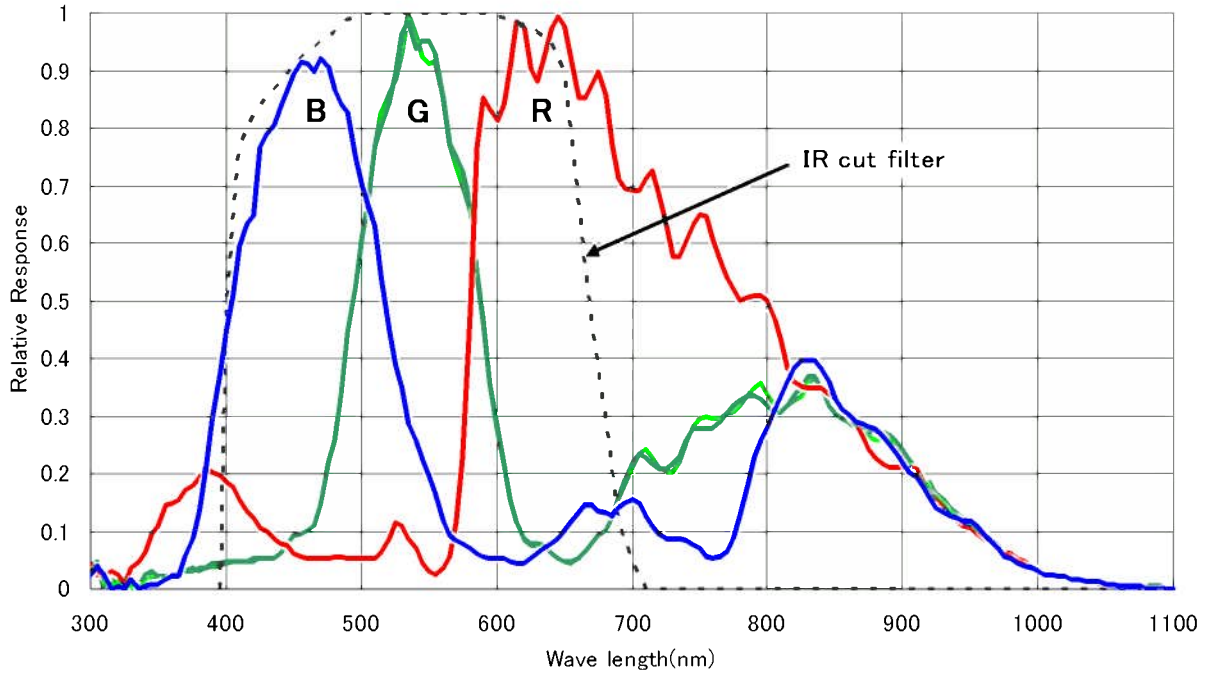

A

B

C

D

E

F

10. External view

- MASS : APPROX 130 g
- UNIT : mm
- SCALE : NTS

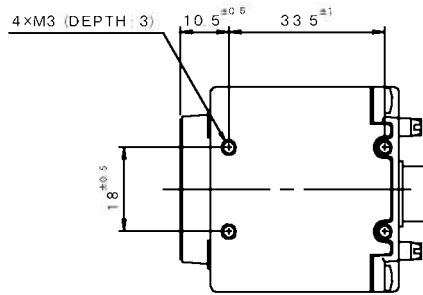
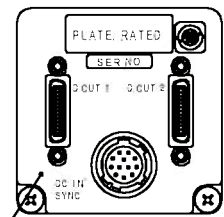
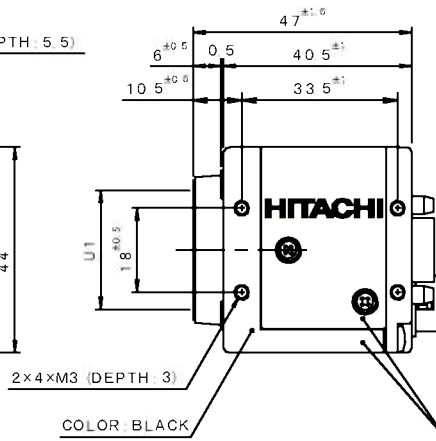
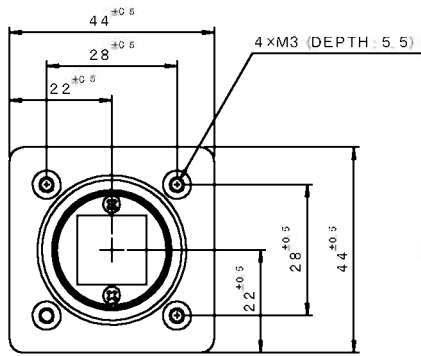
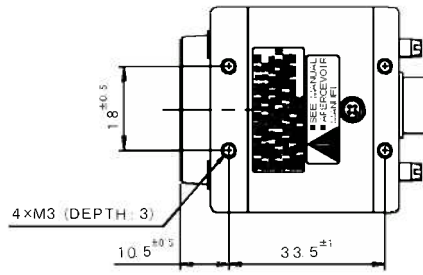

Notice:

These specifications are subject to change without prior notice due to product improvement.

Confirm the most recent specifications at time of order.

Hitachi Kokusai certifies this product complies with the standard warranty conditions of Hitachi Kokusai, and that quality control is implemented to the extent required to comply with these conditions.

RoHS Compliant

This product complies with the requirement of the RoHS(Restriction of the use of Certain Hazardous Substances in Electrical and Electronic Equipment) Directive 2002/95/EC

Warranty and service:

(1) The guarantee period is one year after the data purchase.

However, the defects due to erroneous use or intentional act are excluded.

(2) As the defect after expiration of the guarantee period, where product repair is possible, repair will be performed at charge.

(3) The present Warranty pertains only to the camera unit. Secondary malfunctions attributable to camera failure as well as expenses incurred by disassembly and reassembly of the related system, are beyond the scope of this Warranty.

(4) Compensation for loss of business, loss or damage to software, database and other contingent losses are beyond the scope of this Warranty.

(5) Hitachi Kokusai Electric Inc. is not liable for the losses caused when the equipment is used in a system, use for business trades, production process, medical fields, crime prevention applications, etc.

(6) In the case of camera trouble by miss wiring of cable, it will be considered as out of warranty.

Modification history

A

B

C

D

E

F

A

B

C

D

E

F

SIMBLE	DATE	CORRECTION AND REASONS		DESIGNED

DWG. No. **E400272277**

SHEET
27 / 27