

## Full HD HD-SDI Camera KP-HD2005R-S5

Full HD / CMOS / 0.009 lux / NIR Sensor



- Full HD 2.38 mega-pixel 1/1.9" high sensitivity CMOS image sensor.
- Standard C-mount lens permits use of a wide range of long zoom lenses.
- CMOS sensor produces HD pictures at 30/25 fps, progressive scan output.
- Ultra low-light capability at 0.009 lux  
(COLOR, F1.2, AGC 75dB, GAMMA HIGH, SEN UP:OFF)
- More than 60dB S/N  
(HD-SDI & VBS outputs, AGC 0dB, DETAIL -128, GAMMA OFF)
- Ultra-high sensitivity NIR Sensor Technology. (B&W)
- Camera offers focus output function. When used with Hitachi's IF-PCB interface, it dramatically improves zoom lens Auto Focus speed & accuracy.
- Single cable connectivity for power, video via Coax Cable.



Rear Panel

### Motion Stabilizer

Motion Stabilizer (with Hitachi's VG-2000PCB)  
2000mm Zoom Lens x60 Zoom



Before

After

### Long Range, Low-Light Capability

2000mm zoom lens. 1/2 mile distance, low light

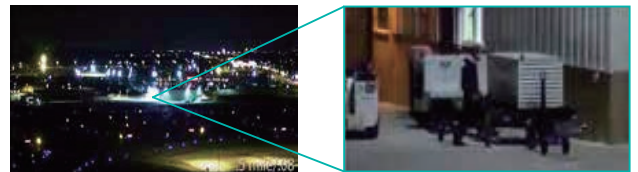

No Zoom

x60 Zoom

### Real Time Heat Haze Correction

Heat & Haze correction, 2000mm Zoom Lens  
x60 Zoom (with Hitachi's VG-2000PCB).



Before

After

### Fog & Smoke Reduction

Adaptive Defog. B&W with Visible Cut Filter allows camera to see through fog in real time.



OFF

ON

# Main Specifications

KP-HD2005R-S5	
Imaging Device	1/1.9 CMOS (RGB Bayer color)
Total pixels	1952(H) X 1241(V) 2.4M pixels
Effective pixels	1937(H) X 1097(V) 2.38M pixels
Imaging System	Progressive 30 fps / 25 fps (P-type)
Sync system	Internal
Video output	HD-SDI (SMPTE292M) & Analog VBS (selectable PAL or NTSC)
Video format	HD-SDI: 1080/59.94i, 1080/29.97P, 1080/50i, 1080/25P
Minimum illumination	Color : 0.009 lux (F1.2 AGC:75dB, Gamma: High, SEN UP OFF) B&W : 0.0005 lux (F1.2 AGC:75dB, Gamma: High, SEN UP OFF) *3200K Tungsten lamp used for testing
S/N ratio	More than 60dB
Resolution	Horizontal resolution more than 800 lines TV lines

OPERATIONAL	
AGC	OFF / Auto (Max Gain 75dB, fog OFF, Max Gain 42dB, fog ON)
Electronic shutter	OFF / AES / Manual (1/30 to 1/100000 sec)
Electronic sensitivity (SEN UP)	OFF / Auto (Max 60 times) / Manual (2 to 30 times)
Fog Reduction	OFF / ON / Auto (1 to 128 levels)
Day & Night (W/B switching)	COLOR / B&W / Auto (ICR)
BLC	OFF / ON (photometry area with ROI capability)
White Balance	Auto : ATW Manual : Manual (2500K – 8000K)

## External dimensions

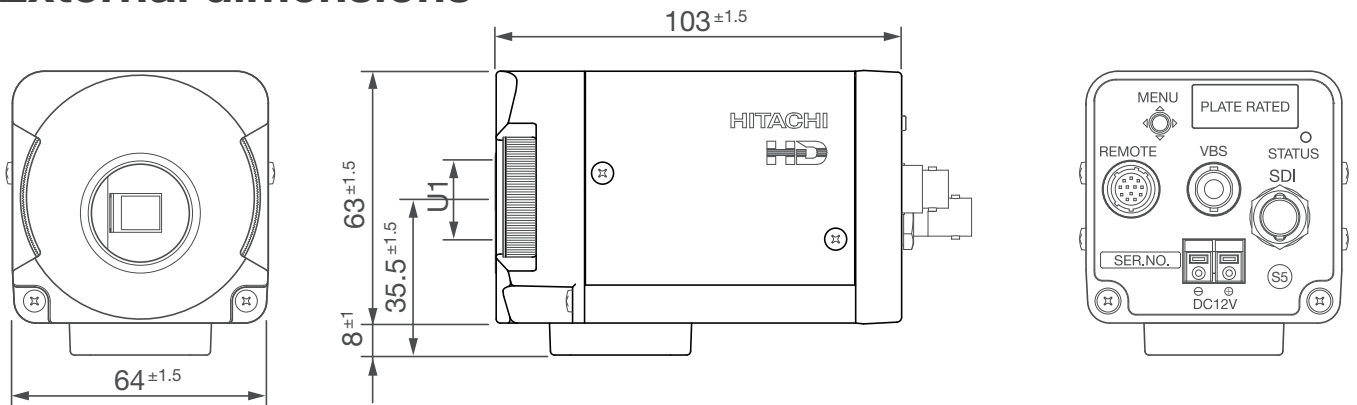

**CAUTION** : To ensure safe operation, please read the instruction manual before using this product.

**Hitachi Kokusai Electric Inc.**  
 32, Miyuki-cho, Kodaira-shi, Tokyo 187-8511, Japan  
 Phone : +81-50-3383-3432, Fax : +81-42-322-3270  
 URL : <https://www.hitachi-kokusai.co.jp/global/en/index.html>

**Hitachi Kokusai Electric Asia (Singapore) Pte. Ltd.**  
 URL: <http://www.hitachi-kokusai.com.sg/>  
 7 Tampines Grande, #02-04 Hitachi Square, Singapore 528736  
 Phone : +65-(0)6212-1945, Fax : +65-(0)6231-2429

**Hitachi Kokusai Electric America, Ltd.** URL: <http://www.hitachikokusai.us/>  
**Headquarters** : 150 Crossways Park Drive, Woodbury, NY 11797, U.S.A.  
 Phone : +1 (516) 921-7200, Fax : +1 (516) 496-3718  
**West Office** : 11258 Monarch Street, Unit H, Garden Grove, CA 92841, U.S.A.  
 Phone : +1 (714) 895-6116, Fax : +1 (714) 895-6252  
**Northeast Sales** : Phone : +1 (860) 757-3892 **South Sales** : Phone : +1 (850) 934-1234  
**Midwest Sales** : Phone : +1 (330) 334-4115 **Latin / Canada Sales** : Phone : +1 (516) 682-4408

These Specifications are subject to change without notice.

**Hitachi Kokusai Electric Europe GmbH** URL : <http://www.hitachi-keu.com/>  
**Frankfurt Head Office** : Siemensstr. 9, D-63263 Neu-Isenburg, Germany  
 Phone : +49(0) 6102-8332-0, Fax : +49(0) 6102-202616  
**London Office** : Orion House, Bessemer Road, Welwyn Garden City,  
 Herts, AL7 1HH, UK  
 Phone : +44(0)7808 330196, Phone : +44 (0) 8451 212177

**Hitachi Kokusai Linear Equipamentos Eletrônicos S/A** URL : <http://www.hitachi-linear.com.br/>  
**Head Office** : Rodovia BR 459, No121-A, Km 121 - Bairro Corrego Raso,  
 Santa Rita do Sapucaí, 37540-000, MG - Brazil  
 Phone : +55 (35) 3473-3473, Fax : +55 (35) 3473-3474  
**Sales Office** : Alameda Santos, 745 - 9 Andar - Conj. 91B, Cerqueira Cesar,  
 São Paulo, 01419-001, SP - Brazil  
 Phone : +55 (11) 3541-3244, Fax : +55 (11) 3541-2425